

# Lembar data produk

Spesifikasi



## circuit breaker Easypact EZC100H - TMD - 100 A - 2 poles 2d

EZC100H2100

### Main

Range of product	EasyPact
Product or component type	Circuit breaker
Device short name	Easypact EZC100H
Circuit breaker name	Easypact EZC100H
Device application	Distribution
Poles description	2P
Protected poles description	2t
Network type	AC DC
Network frequency	50/60 Hz
[In] rated current	100 A at 40 °C
[Ui] rated insulation voltage	690 V AC 50/60 Hz conforming to IEC 60947-2
[Uimp] rated impulse withstand voltage	6 kV conforming to IEC 60947-2
[Ue] rated operational voltage	550 V AC 50/60 Hz conforming to IEC 60947-2 250 V DC conforming to IEC 60947-2
Breaking capacity code	H
Breaking capacity	10 kA Icu at 125 V DC 1P conforming to IEC 60947-2 10 kA Icu at 250 V DC 2P conforming to IEC 60947-2 10 kA Icu at 550 V AC 50/60 Hz conforming to IEC 60947-2 100 kA Icu at 110...130 V AC 50/60 Hz conforming to IEC 60947-2 20 kA Icu at 440 V AC 50/60 Hz conforming to IEC 60947-2 30 kA Icu at 380 V AC 50/60 Hz conforming to IEC 60947-2 30 kA Icu at 400...415 V AC 50/60 Hz conforming to IEC 60947-2 50 kA Icu at 220...240 V AC 50/60 Hz conforming to IEC 60947-2
[Ics] rated service breaking capacity	15 kA at 380 V AC 50/60 Hz conforming to IEC 60947-2 5 kA at 125 V DC conforming to IEC 60947-2 5 kA at 250 V DC conforming to IEC 60947-2 50 kA at 110/130 V AC 50/60 Hz conforming to IEC 60947-2 5 kA at 440 V AC 50/60 Hz conforming to IEC 60947-2 2.5 kA at 550 V AC 50/60 Hz conforming to IEC 60947-2 7.5 kA at 400/415 V AC 50/60 Hz conforming to IEC 60947-2 25 kA at 220/230/240 V AC 50/60 Hz conforming to IEC 60947-2
Suitability for isolation	Yes conforming to IEC 60947-2
Utilisation category	Category A
Trip unit name	TM-D
Trip unit technology	Thermal-magnetic
Trip unit rating	100 A at 50 °C

<b>Protection type</b>	Overload protection Short-circuit protection
<b>Pollution degree</b>	3 conforming to IEC 60664-1 3 conforming to IEC 947-1

## Complementary

<b>Control type</b>	Toggle
<b>Mounting mode</b>	Fixed
<b>Mounting support</b>	Backplate
<b>Upside connection</b>	Front
<b>Downside connection</b>	Front
<b>Mechanical durability</b>	8500 cycles
<b>Electrical durability</b>	Category A: 1500 cycles 415 V AC 50/60 Hz conforming to IEC 60947-2
<b>Connection pitch</b>	25 mm
<b>Local signalling</b>	Positive contact indication
<b>Neutral protection setting</b>	Without protection
<b>Earth-leakage protection</b>	Without
<b>Height</b>	130 mm
<b>Width</b>	50 mm
<b>Depth</b>	60 mm

## Environment

<b>Standards</b>	EN/IEC 60947-1 GB/T 14048.2 JIS C8201-2-2 EN/IEC 60947-2
<b>IP degree of protection</b>	IP20 conforming to IEC 60529
<b>IK degree of protection</b>	IK07 conforming to IEC 62262
<b>Ambient air temperature for operation</b>	-25...70 °C
<b>Ambient air temperature for storage</b>	-35...85 °C

## Packing Units

<b>Unit Type of Package 1</b>	PCE
<b>Number of Units in Package 1</b>	1
<b>Package 1 Height</b>	9.5 cm
<b>Package 1 Width</b>	14.0 cm
<b>Package 1 Length</b>	6.0 cm
<b>Package 1 Weight</b>	571.0 g
<b>Unit Type of Package 2</b>	S02
<b>Number of Units in Package 2</b>	18
<b>Package 2 Height</b>	15.0 cm
<b>Package 2 Width</b>	30.0 cm
<b>Package 2 Length</b>	40.0 cm
<b>Package 2 Weight</b>	10.664 kg
<b>Unit Type of Package 3</b>	P12

<b>Number of Units in Package 3</b>	576
<b>Package 3 Height</b>	75 cm
<b>Package 3 Width</b>	120 cm
<b>Package 3 Length</b>	80 cm
<b>Package 3 Weight</b>	353 kg

## Offer Sustainability

<b>Sustainable offer status</b>	Green Premium product
<b>REACH Regulation</b>	<a href="#">REACH Declaration</a>
<b>REACH free of SVHC</b>	Yes
<b>EU RoHS Directive</b>	Compliant <a href="#">EU RoHS Declaration</a>
<b>Toxic heavy metal free</b>	Yes
<b>Mercury free</b>	Yes
<b>China RoHS Regulation</b>	<a href="#">China RoHS declaration</a>
<b>RoHS exemption information</b>	<a href="#">Yes</a>
<b>Environmental Disclosure</b>	<a href="#">Product Environmental Profile</a>
<b>WEEE</b>	The product must be disposed on European Union markets following specific waste collection and never end up in rubbish bins

## Contractual warranty

<b>Warranty</b>	12 months
-----------------	-----------

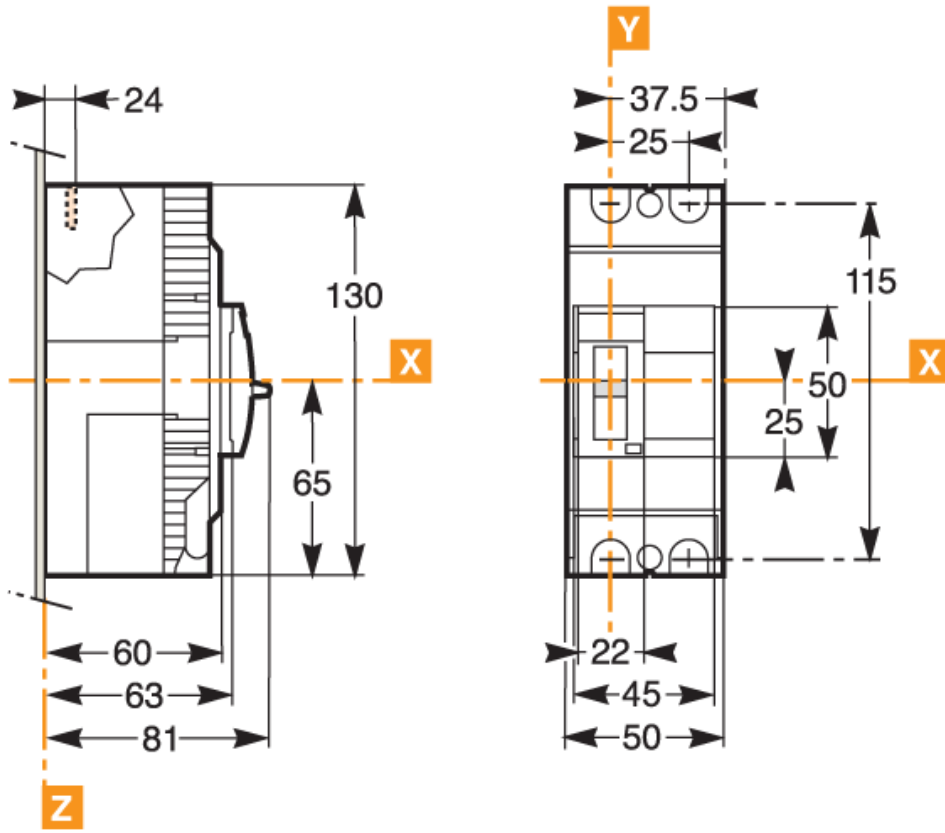

Lembar data produk

EZC100H2100

Assembly

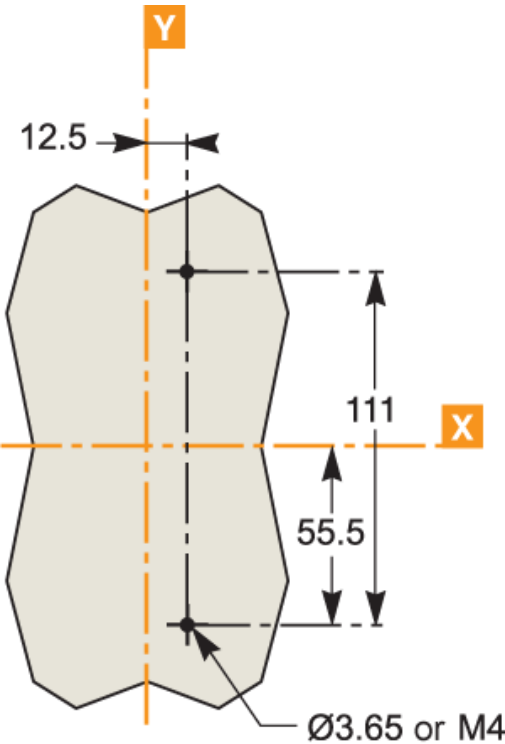

Performance Curves

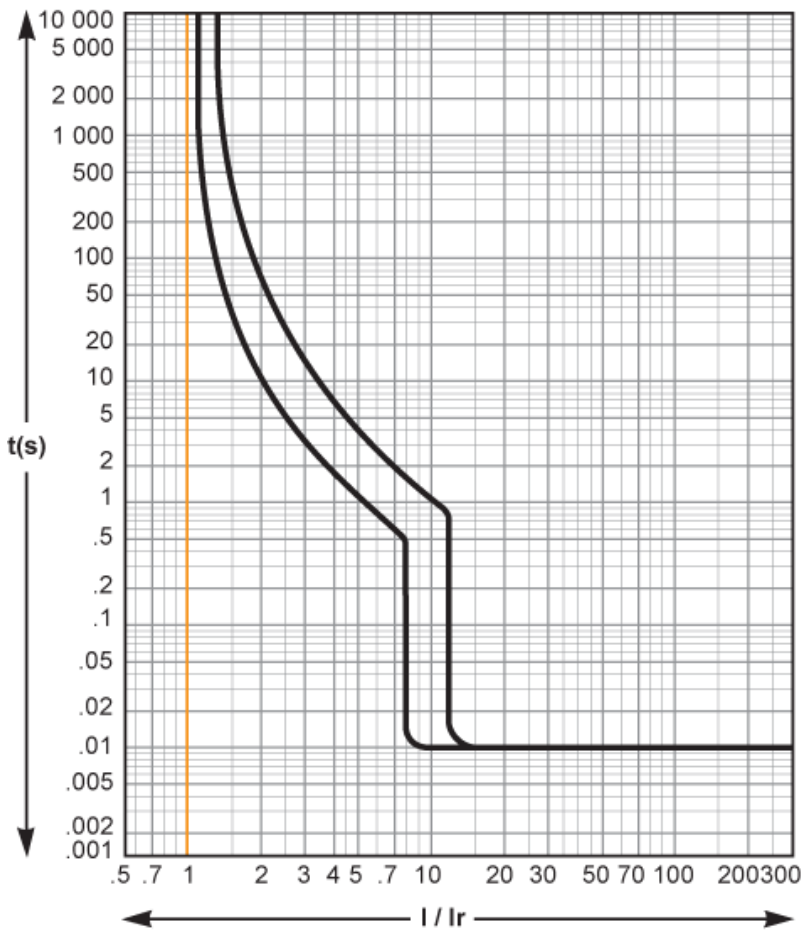

Penggantian yang disarankan